

One Palaeua Bay

Plot Plan For Lot 11

Total Lot Area: 69,689 Sq. Ft.
 Building Area: 38,121 Sq. Ft.
 Maximum Building Height Above Grade: 18 Ft. For One Story Portion
 Maximum Building Height Above Grade: 28 Ft. For Two Story Portion

Street Address and Name:
 Pohuehue Place
 T.M.K.: (2)2-1-023:002
 Setbacks:
 Front: 25 Ft.
 Rear: Varies
 Side: 15 Ft.

Palaeua Developers, L.L.C.

2005 Main Street
 Wailuku, HI 96793
 (808) 244-1500

- No Access Permitted
- 10.00 Lot Dimensions
- Utility-Drn., Wtr., Swr., Elec.
- Transformer
- Drainage Flow Line
- St. Light Std.
- Property Line
- Building Limit Area
- Buildable Area
- CRM Wall

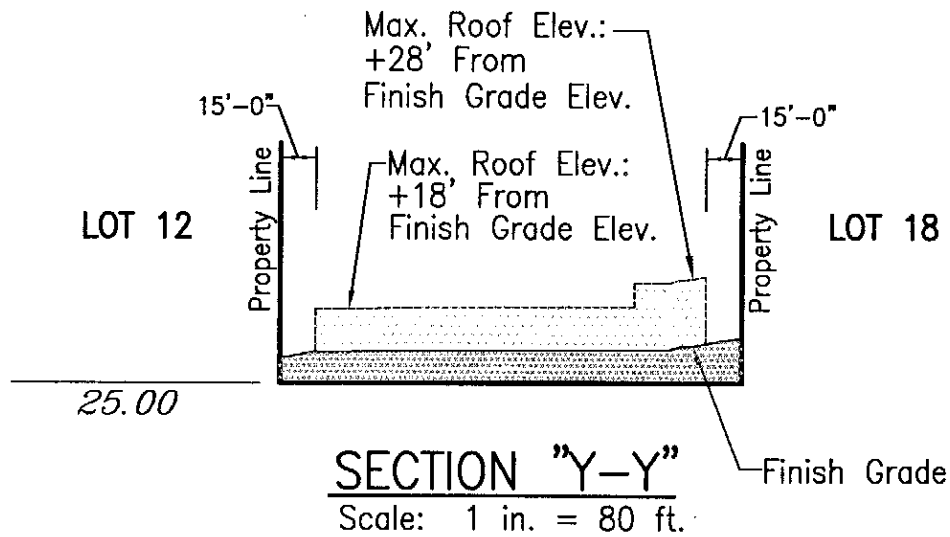
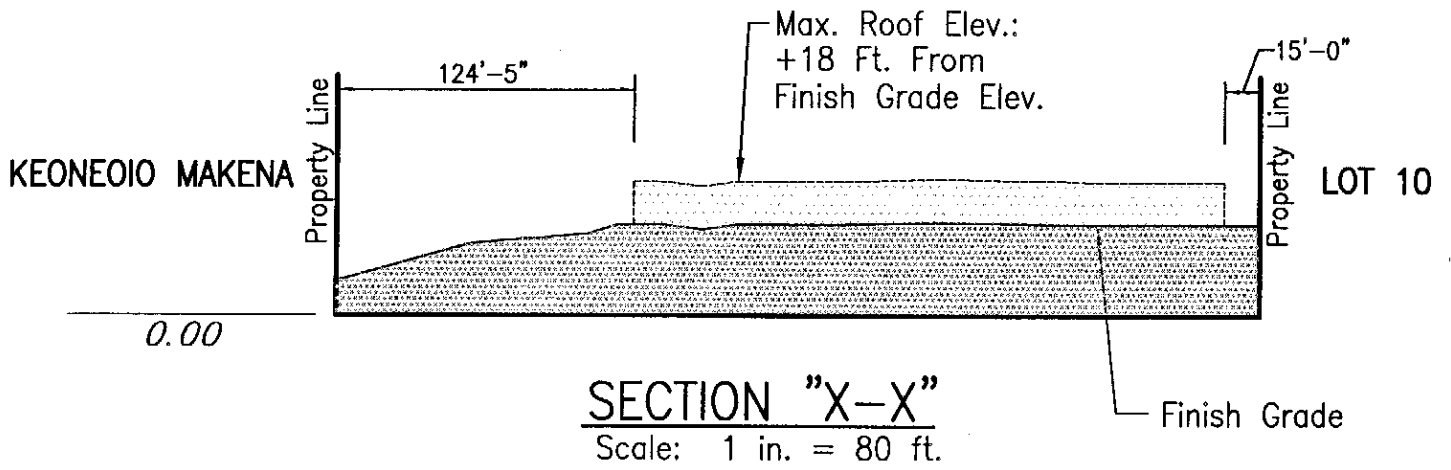

LOT 11

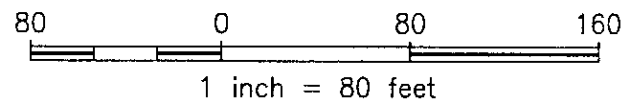

One Palauea Bay

Plot Plan For Lot 11

Total Lot Area: 69,689 Sq. Ft.
 Building Area: 38,121 Sq. Ft.
 Maximum Building Height Above Grade: 18 Ft. For One Story Portion
 Maximum Building Height Above Grade: 28 Ft. For Two Story Portion

Street Address and Name:
 _____ Pohuehue Place
 T.M.K.: (2)2-1-023:002

Setbacks:
 Front: 25 Ft.
 Rear: Varies
 Side: 15 Ft.

Palauea Developers, L.L.C.

2005 Main Street
 Wailuku, HI 96793
 (808) 244-1500

- | | | | |
|--|---------------------------------|--|---------------------|
| | No Access Permitted | | St. Light Std. |
| | 10.00 Lot Dimensions | | Property Line |
| | Utility-Drn., Wtr., Swr., Elec. | | Building Limit Area |
| | Transformer | | Buildable Area |
| | Drainage Flow Line | | CRM Wall |

Notes:

1. The development of this Lot must comply with the Declaration of Covenants, Conditions and Restrictions for One Palaeua Bay.
2. Lot buyer shall verify all topography, soil conditions, drainage, fill conditions, utilities, easements, and street trees in the field. Plot plan is informational only and does not constitute any commitment, representation or warranty with respect to the foregoing items. Palaeua Developers L.L.C. hereby disclaims, and lot buyer hereby acknowledges that no representation, expressed or implied, has been made with respect to existing or future view planes.

One Palaeua Bay

Plot Plan For Lot 11











Total Lot Area: 69,689 Sq. Ft.
 Building Area: 38,121 Sq. Ft.
 Maximum Building Height Above Grade: 18 Ft. For One Story Portion
 Maximum Building Height Above Grade: 28 Ft. For Two Story Portion

Street Address and Name:
 _____ Pohuehue Place
 T.M.K.: (2)2-1-023:002

Setbacks:
 Front: 25 Ft.
 Rear: Varies
 Side: 15 Ft.

Palaeua Developers, L.L.C.

2005 Main Street
 Waifuku, HI 96793
 (808) 244-1500

	No Access Permitted		St. Light Std.
10.00	Lot Dimensions		Property Line
  	Utility-Drn., Wtr., Swr., Elec.		Building Limit Area
	Transformer		CRM Wall
	Drainage Flow Line		